

Aquitron

AT-MZA

Multi Zone Alarm



DATA SHEET



aquilar
leak detection solutions



AT-MZA

Multi Zone Alarm

The AquiTron MZA multiple zone alarm panel is designed for use with all TraceTek sensing cables and AquiTron sensors to detect liquid. The AT-MZA comes with 2 zones as standard, however with the addition expansion cards is capable of monitoring up to 8 individual sensing zones, making it a truly versatile panel. The AT-MZA provides both visual and audible indication when a leak or cable fault has occurred. There are relay contacts to connect each zone to other equipment such as BMS, PLC's, other alarm and monitoring systems.

SIMPLE OPERATION

The panel display includes LEDs for each zone. In the event of a leak, the alarm sounds and the LED indicates the zone where the leak has occurred. The operator silences the alarm by pressing the external MUTE button. The LED's located on the front faceplate indicate power, (mains or battery back-up), alarm, leak alarm and cable break. Once the alarm has been silenced, the red alarm LED will stop flashing to indicate the system has been acknowledged and the appropriate zone leak or cable break LED will also stay illuminated. Once the cause has been located and corrected the panel can be reset and the corresponding LED will automatically be extinguished. Pressing the reset button also resets the volt free alarm relay contacts. Any loss of system integrity, whether caused by an interruption of power or a break in a sensing circuit, will be indicated by the panel's display and the fault relay contacts.

VERSATILE DESIGN

The MZA metal enclosure can be easily mounted to a wall or other flat surface. A semi-flush mounting flange is also available. The enclosure is lockable, has an IP54 rating and a 90 decibel audible alarm. Easy connection via volt free relays to external equipment such as BMS or isolation valves. An auxiliary remote alarm (AT-RAP) can be added to the system for remote locations such as reception areas and security rooms. The AT-MZA unit operates on 230/120Vac (50/60HZ) and 12Vdc. A battery enclosure unit (AT-BU) for 24-hour operation is also available.

APPLICATIONS

The AT-MZA is ideally suited for multiple integration into centralised monitoring systems for computer rooms or large facilities, as well as interfacing into control systems for air conditioning and fan coil units, pump, booster and generator sets. There are individual volt free leak alarm relays for each of the 8 zones, additional summary relays are included for leak and cable break/power failure. Typical applications include monitoring leaks that would occur around individual air-handling units, water-cooled machinery, tanks, pumps, sumps or other locations.

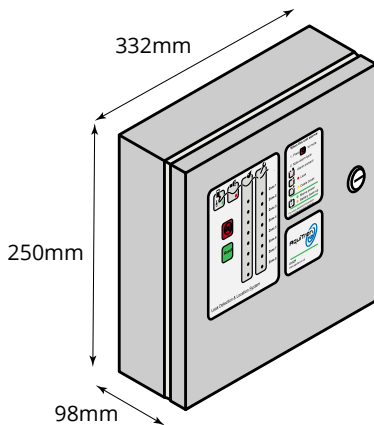

TECHNICAL INFORMATION

Sensing cable compatibility	All TraceTek sensing cable (TT1000, TT1100, 3000, 5000, 5001, 7000)
Detection Probes	Water detection probes, optical oil sensors and immersion sensors
Maximum sensing circuit	100 metres (328 ft) per zone, 10 x AT-PROBE-M/TS
Enclosure	Powder coated steel, colour RAL 7032, IP54, lockable
Humidity	5% to 95% non-condensing
Power supply	230/120Vac, 50/60Hz, 12Vdc, 7 watts
Relay Output	3A 250Vac / 24Vdc. SPDT. Volt free relay contacts activated by leak or cable fault (NC/COM or NO/COM)
Status LED	Power (Mains-Green, Battery-Red), Alarm (red flashing), Leak (Red), Cable break (Yellow)

APPROVALS

Electromagnetic compatibility (EMC)

CE	Compliant with standards for emissions	EN61000-6-2:1999 (Heavy industrial)
	Compliant with standards for immunity	EN50081-1

ORDERING INFORMATION

Catalogue number	3560 AT-MZA Multi Zone Alarm
	3655 AT-MZA-EXP Expansion Card (2 zones per card)

ANCILLARY PRODUCTS

3660 AT-MZA-SFMF Semi Flush Mounting Flange
3485 AT-BU Battery Unit
2335 AT-RAP Remote alarm panel (230Vac)

CONFIGURATION EXAMPLES

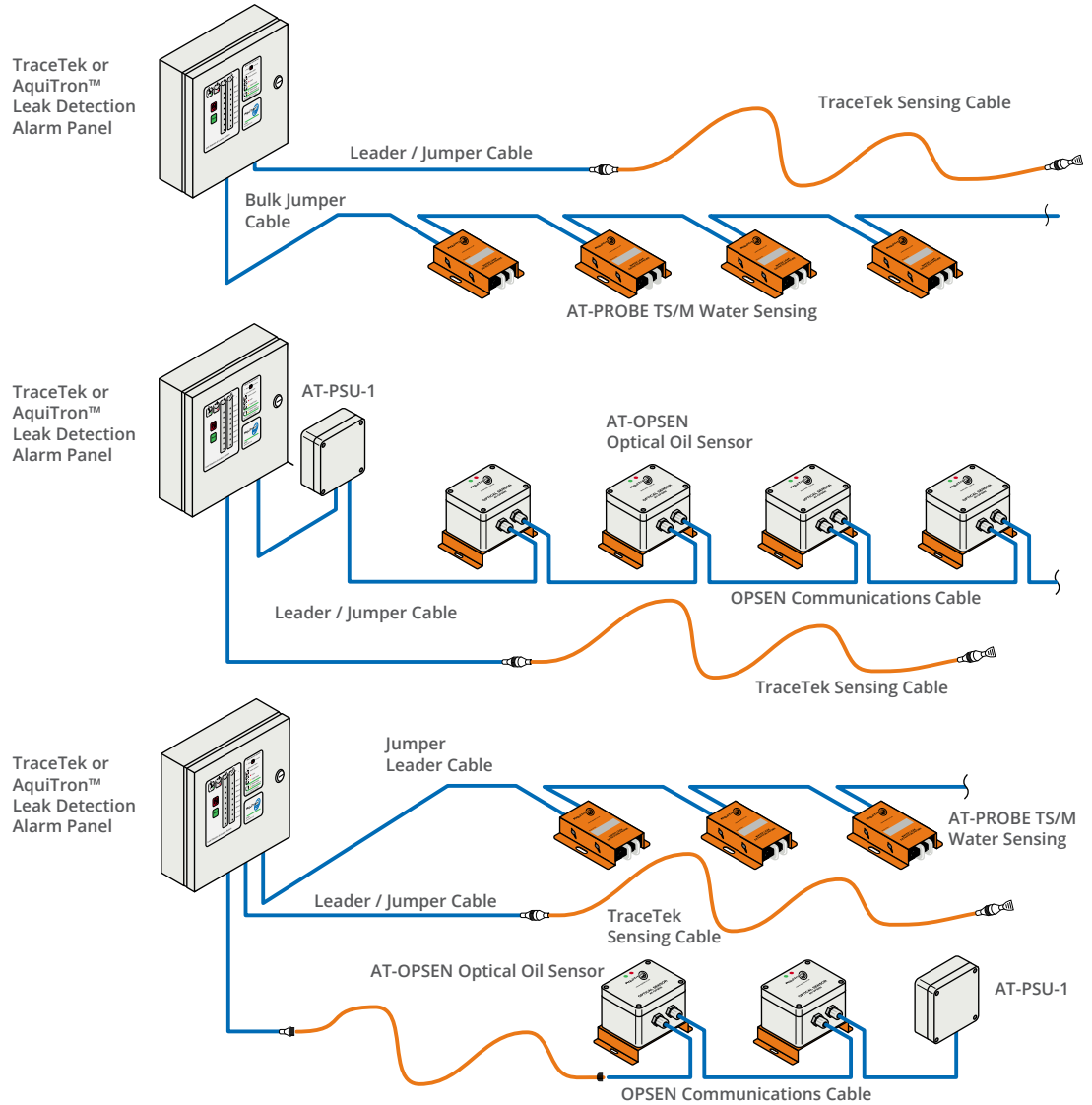

Important: All information, including illustrations, is believed to be reliable. Users, however, should independently evaluate the suitability of each product for their application. Aquilar Limited makes no warranty as to the accuracy or completeness of the information, and disclaims any liability regarding its use. The only obligations of Aquilar Limited are those in the Aquilar Standard Terms and Conditions of Sale for this product, and in no case will Aquilar Limited be liable for any incidental, indirect, or consequential damages arising from the sale, resale, use or misuse of the product. Specifications are subject to change without notice. In addition, Aquilar Limited reserves the right to make changes - without notification to Buyer - to processing or materials that do not affect compliance with any applicable specification.

*AquiTron is a trademark of AquiTron Limited
 Aquilar is a trademark of Aquilar Limited*