

FOSC 600

Fiber Optic Splice Closure

The FOSC 600 C and D closures are more than just fiber optic splice closures. They are rugged and versatile platforms that can be deployed anywhere in the outside plant for a multitude of functions including the splicing of most any type and size of cable, the housing of connectorized distribution and demarcation points, and the deployment of optical passives.

The sealing system for FOSC 600 closures builds on the proven reliability of FOSC 400 and FOSC 450 closures and features the versatile and popular gel-sealing technology for terminating cables, and a unique latching system for quickly opening and closing the body.

Features

- Butt or inline splice closure
- Gel-seal technology
- Hinging trays
- Large fiber capacity
- Superior fiber management
- Excellent consolidation or rehabilitation closure

Other features include:

- Up to 16 separate cable ports
- Sized for cables up to 35mm in diameter and 1728 fibers
- Field configurable for butt or in-line splicing
- All internal parts can be removed for reconfiguration
- Both C and D closures use CommScope's "D" size splice trays
- Storage basket included with all closures can be extended in length or repositioned vertically depending on application
- Slack ribbon storage on the same tray as mass fusion splices is possible with use of a ribbon tray
- Backed by CommScope's extensive network of technical field support specialists.

FOSC 600

Fiber Optic Splice Closure

Selection Guide

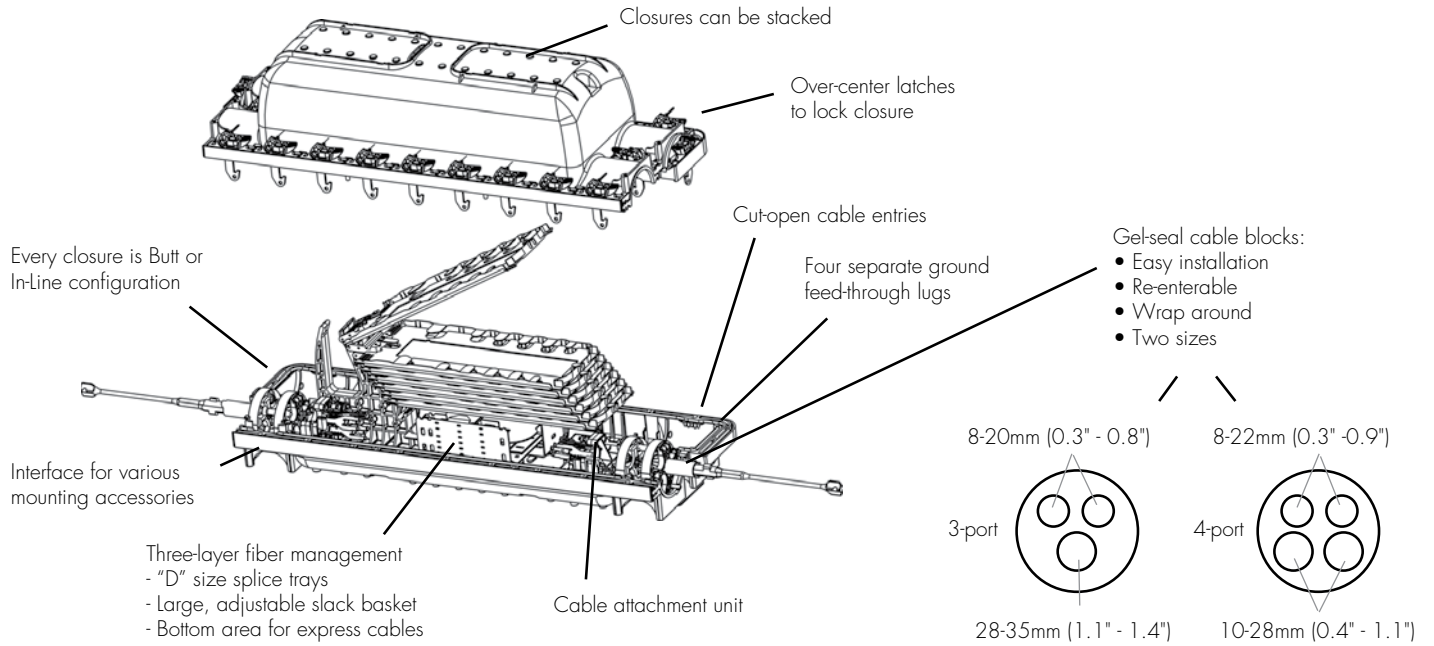

FOSC 600

Fiber Optic Splice Closure

Ordering Information

FOSC 600 - X X X - XX - X - X X X

Closure Size

C	600 C
D	600 D

Number of Drop Cable Parts

4	One 4-port gel block
6	Two 3-port gel blocks
8	Two 4-port gel blocks

Configuration

B	Butt
I	In-Line
R	Reverse Butt*

Capacity (or type) of Splice Trays

36	D tray with six SM6 modules*
72	D tray with six SM12 modules 96
R2	D ribbon tray (splice capacity: 24, 12 fiber ribbon splices)
NT	No trays

Valve for Flash Test

V	V for valve is standard
---	-------------------------

Number of Ground Feed-Through Lugs

0	0 lugs
2	2 lugs
4	4 lugs

Slack Basket Type

C	Standard
D	Basket for D version
N	No basket
L	Loose buffer tube ribbon modification (D size only). No basket included.
M	Same as "L" above, but includes storage basket.

Number of Splice Trays

0 or 1	0 or 1 is standard
--------	--------------------

*For use when increased fiber lengths on tray is required and loose buffer tube cable reverse point is offset in main cable opening.

FOSC 600

Fiber Optic Splice Closure

Closure Dimensions in Inches (cm)

Description	Length	Height	Width
600 C	32.6 (82.8)	6.0 (15.2)	10.8 (27.4)
600 D	32.6 (82.8)	10.0 (25.4)	10.8 (27.4)

Tray (and splice) Capacity of Closures

Description	D Splice Trays	D-Ribbon Tray ¹
600 C In-line	3 (216)	2 (576)
600 C Butt	5 (360)	3 (864)
600 D In-line	7 (504)	4 (1152)
600 D Butt	9 (648)	6 (1728) ²

¹ Ribbon splice capacity is 2592 fibers based on using 6,D-36 style trays with slack storage in storage basket.

² L Basket type closures capacity is 5 D-Ribbon trays (1440 fibers).

Accessories

FOSC-ACC-D-Tray-36	D size tray with six SM6 modules
FOSC-ACC-D-Tray-72	D size tray with six SM12 modules
FOSC-ACC-D-Tray-Ribn24	D size ribbon tray (24 mass fusion splices)
FOSC600-GelSeal-3	3-port cable seal
FOSC600-GelSeal-4	4-port cable seal



www.commscope.com

Visit our website or contact your local CommScope representative for more information.

© 2016 CommScope, Inc. All rights reserved.

All trademarks identified by ® or ™ are registered trademarks or trademarks, respectively, of CommScope, Inc. This document is for planning purposes only and is not intended to modify or supplement any specifications or warranties relating to CommScope products or services.

PA-317451.2-AE (05/16)